

Sparkle: Hover Feedback with Touchable Electric Arcs

Daniel Spelmezan

Deepak Ranjan Sahoo¹

Sriram Subramanian

Interact Lab

University of Sussex, Brighton, UK

d.spelmezan@sussex.ac.uk, deepakranjan@gmail.com, sriram@sussex.ac.uk

ABSTRACT

Many finger sensing input devices now support proximity input, enabling users to perform in-air gestures. While near-surface interactions increase the input vocabulary, they lack tactile feedback, making it hard for users to perform gestures or to know when the interaction takes place. Sparkle stimulates the fingertip with touchable electric arcs above a hover sensing device to give users in-air tactile or thermal feedback, sharper and more feelable than acoustic mid-air haptic devices. We present the design of a high voltage resonant transformer with a low-loss soft ferrite core and self-tuning driver circuit, with which we create electric arcs 6 mm in length, and combine this technology with infrared proximity sensing in two proof-of-concept devices with form factor and functionality similar to a button and a touchpad. We provide design guidelines for Sparkle devices and examples of stimuli in application scenarios, and report the results of a user study on the perceived sensations. Sparkle is the first step towards providing a new type of hover feedback, and it does not require users to wear tactile stimulators.

Author Keywords

In-air feedback; Electric discharge; High voltage resonant transformer; Hover input; Infrared proximity sensor.

ACM Classification Keywords

H.5.2. [Information Interfaces and Presentation (e.g. HCI)]: User Interfaces—Haptic I/O.

INTRODUCTION

Proximity sensing technologies have enabled users to control computing devices with finger gestures performed above the input surface (e.g., mobile devices' touchscreens [7], touchpads [8, 12], keypads [31], tabletops [29, 36] and walls [23]), and to seamlessly interact with the physical surface and with the space above it [7, 16, 21]. Unlike touch, in-air gestures lack natural tactile feedback, which can make it hard for users to precisely perform a gesture and to manipulate the content with only proprioceptive feedback [38]. This difficulty is

¹FIT Lab, Department of Computer Science, Swansea University, Swansea, UK

Permission to make digital or hard copies of all or part of this work for personal or classroom use is granted without fee provided that copies are not made or distributed for profit or commercial advantage and that copies bear this notice and the full citation on the first page. Copyrights for components of this work owned by others than ACM must be honored. Abstracting with credit is permitted. To copy otherwise, or republish, to post on servers or to redistribute to lists, requires prior specific permission and/or a fee. Request permissions from Permissions@acm.org.

CHI 2017, May 06–11, 2017, Denver, CO, USA
 © 2017 ACM. ISBN 978-1-4503-4655-9/17/05...\$15.00
 DOI: <http://dx.doi.org/10.1145/3025453.3025782>

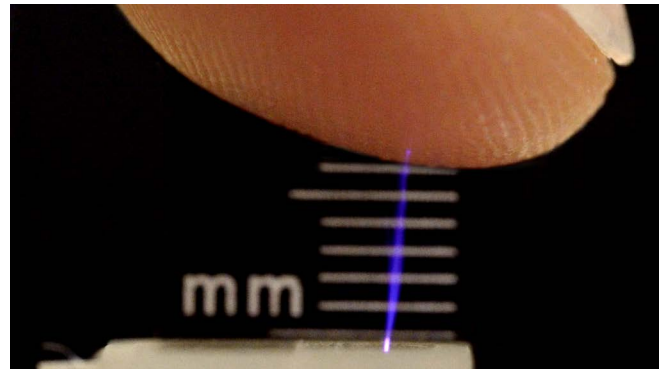

Figure 1. Touchable electric arcs spark tactile and thermal sensations.

most apparent for hover gestures when users have to position and maintain the height of their finger without performing a touch or leaving the hover range.

Here we present SPARKLE, a technology that enables tactile and thermal feedback for hover input with controlled electric arcs that are safe to touch (see Figure 1). To stimulate the fingertip we augment a finger sensing input device with a high voltage resonant transformer and trigger mild electric discharges when the finger is near the surface. We control the moment when the discharge occurs and the duration of the discharge, and we modulate the discharge from resonant frequency down to a frequency detectable by the receptors in the fingertip to alter its intensity and to create stimuli of discrete and of continuous trains of arcs that can elicit tickling, tingling, warm and hot sensations.

Unlike previous solutions to facilitate the input and to give haptic feedback for hover gestures, SPARKLE does not attach an actuator to the finger (e.g., a laser-light absorbing medium [19], a piezo [30], or a magnet [39]), which is undesirable to wear for casual in-air interactions. Unlike focused airborne ultrasound [6, 25], SPARKLE enables a shorter working distance and creates sharper sensations suitable for hover interactions. Recently, body-carried electrostatic charge was proposed for mobile scenarios to give users a controlled electric shock when touching a conductive object, or to exert force onto lightweight particles (e.g., sand) very near to the fingertip [26]. This approach necessitates continuously charging the user with a wearable high voltage DC charger, who cannot selectively prevent the discharge (e.g., when touching another person or when grasping a door handle). Moreover, body-carried charge does not scale from giving a momentary elec-

tric shock to providing in-air feedback on demand, or over a longer time period. Finally, the integration with hover sensing has not been shown.

In this work we describe the operating principle and show how to integrate in-air feedback from touchable electric arcs into a proximity sensing device with size similar to a button. We then address the feasibility of scaling of this technology to instrument a touchpad-sized surface. Finally, we explore the sensations we were able to create at the fingertip. Our main goal with this work is to introduce the technology and to give example sensations from electric arcs.

Our contributions are:

- A technology for creating touchable electric arcs using a high voltage resonant transformer and a self-resonating driver circuit.
- A finger sensing device that gives users in-air tactile and thermal feedback for hover.
- An initial exploration of the design space of sensations from touchable electric arcs.

RELATED WORK

Our work is related to haptic feedback technologies that stimulate the fingers in air and to tactile feedback technologies that use electric current or electric shocks to create sensations.

In-air haptic feedback

Mechanical actuators

Physical actuators (e.g., vibration motors) offer a simple but for casual in-air interactions an undesirable solution to stimulate the fingers above an interactive surface. In Senseable-Rays a piezo and a photo sensor were mounted to the dorsal side of the finger to turn time-modulated light signals into vibration feedback [30]. However, this device can be uncomfortable to wear and necessitates a power source, either wearable or tethered. In FingerFlux [39] a small permanent magnet attached to the fingertip created vibration, attractive and repulsive force feedback in close proximity to the tablet surface, using magnetic fields generated from electromagnets built into the table. The downside is that the magnet obstructs the fingertip and hinders direct touch input.

Airborne ultrasound

With new technologies that can focus airborne ultrasound the hands and fingers do not need to be equipped with physical actuators to perceive in-air haptic sensations [6, 25]. The ultrasound beams can pass through a perforated sheet or a loosely woven fabric used as display surface for top-projection [6], and can be redirected by a specular reflector towards the target [25]. However, the sensation can be perceived only when the hands are 15-20 cm away from the transmitter array due to the distance needed to focus the beams. Another disadvantage is the low-resolution (approximately 1 cm) and subtleness of the sensation, which users tend to prefer for continuous feedback [11].

Air vertices and air suction

Another approach to enable in-air feedback are air cannons, which shoot air vertices at the user to complement mid-air

gestures with tactile sensations or to stimulate larger body areas from a distance [13, 33]. The disadvantages are the low targeting resolution and the low resolution of the sensations (5–8.5 cm at 1 meter distance). However, air jets can give users force feedback on a top-projected interactive surface by releasing compressed air through nozzles built into the surface (e.g., to impart force onto a handheld tool shaped like a cup) [35]. In the reverse direction air suction can provide force feedback through a perforated projection sheet through which a vacuum pump attracts the user's finger [14].

Laser light

Recently, laser light has been used to create tap-like [19] and impulse sensations at the fingertip [27]. The indirect laser-light stimulation utilizes the thermoelastic deformation of a laser-light absorbing medium attached to the skin (e.g., acrylic tape) to create mechanical waves that stimulate the mechanoreceptors [19]. The direct laser-light stimulation creates a diminutive, touchable aerial image, but the laser necessitates an intensity that is strong enough to create a visible image and weak enough to avoid damaging the skin [27]. This technology has not been developed further, which leaves open questions about the scalability to larger images and the safety of touching those images.

Surface haptics with electricity

Electrotactile and electrovibration stimulation

Our work is strongly related to electrotactile stimulation with which current is directly transmitted from a surface electrode into the skin to stimulate the cutaneous nerves [17, 18]. Unlike electrotactile feedback, electrovibration creates a tactile sensation indirectly through electrostatic attraction forces [4] or through reverse electrovibration for which a weak electrical signal is directly injected into the user's body [5]. Electro-vibration can be perceived only when the user slides the finger over the surface. Another indirect stimulation technique that requires the user to move the finger over the surface to perceive a tactile sensation is based on ultrasound friction (squeeze-film effect) [20].

Electrostatic discharge from static electricity

Our work is also related to a naturally occurring electrostatic discharge from body-carried charge, which we can experience in daily life when the voltage potential difference between our body and a conductive object is large enough to be felt as an electrostatic shock (e.g., 3–10 kV). Upon touching the object the electrons jump from the body across microscopic air gaps to restore the charge imbalance, thereby creating a minute spark. The flow of electrons through the skin can cause an unpleasant sensation for which the intensity depends on the amount of body-carried charge. Some commercial products actually use stingy electric shocks for entertainment (e.g., game controllers for shock tanks).

Corona [26] uses an electrostatic discharge to create a haptic sensation from body-carried charge. However, it works only when the user receives an electric shock when touching a conductive object and is not proposed to create sensations when hovering. To accomplish the high voltage needed to initiate the electrostatic discharge, the system continuously charges

the user's body with a wearable high voltage DC power supply and controls the magnitude of the induced charge (around 4.5 kV) to adjust the intensity of the electric shock. However, the user cannot selectively prevent the discharge, for example, when touching another person. Moreover, the system does not scale to designing stimuli in the time domain due to the slow response of the high voltage power supply. Unlike this system, which can create a sensation only for a direct touch event, SPARKLE can continuously emit and control electric arcs from a high voltage resonant transformer (AC with no net charge) to create in-air tactile or thermal sensations for hover input above a proximity sensing device.

Perception of electric current

Unexpected electric shocks from just-perceptible but non-lethal currents can result in serious accidents as a secondary effect (e.g., caused by involuntary movements or loss of balance due to muscle contraction) [9, 10]. To establish safety guidelines for avoiding electric shocks from electric home appliances researchers conducted many studies on the perception threshold of electric current. Relevant to our work is that current can create many different sensations, which can help us to estimate the sensations from touchable electric arcs.

Current perception thresholds

Dalziel and Mansfield [9, 10] estimated the perception threshold of electric current with copper wires that participants held in their palm, which was moistened with a salt-water solution to ensure good electrical contact, or touched with their middle finger. For low voltages supplied from commercial AC and DC batteries (20–100 V) the approximate thresholds were 1 mA for 60 Hz, 7 mA for 5 kHz, and 5 mA for DC. These findings are difficult to generalize to kilovolts because the body impedance and the skin resistance become negligible at high voltages, and the current instantly penetrates the skin.

Sensations

Alternating current at commercial voltages can create many different sensations [9, 10]. Low frequency current (e.g., 60 Hz) above the detection threshold creates piercing sensations described as sharp, tingling, or pricking. The intensity decreases for higher frequencies, and the sensation becomes smoother, softer and larger (above 1 kHz). Increasing the frequency further creates sensations like “the hand goes to sleep” (10 kHz), pressure (30–90 kHz), and heat (above 100 kHz). However, the sensations and the perception thresholds also depend on the skin contact location and the condition of the skin. With intact skin the participants perceived a sensation of warmth, whereas with damaged skin the sensation was sharp and piercing at low currents.

Direct current pulses can create sensations like tingling, prickling, buzzing, pressure, and pain, which depend on several parameters (e.g., voltage and current magnitude, waveform, electrode and skin characteristics) [17]. A coaxial electrode can elicit vague pressure or vibratory sensations when the center electrode is used as cathode or anode, respectively [18]. Other findings indicate that direct current stimulation causes a sensation of warmth and tingling, which can persist when the current is turned off, suggesting that the nerves are excited by biochemical changes in the tissue [22].

SPARKLE

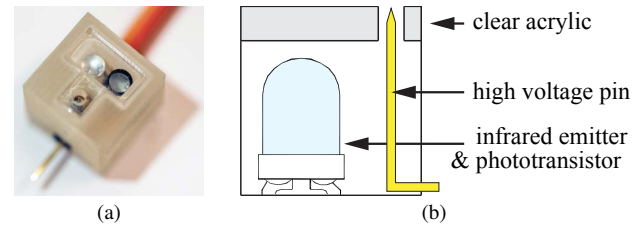

Figure 2. (a) Our prototype has the size of a keyboard button and can fit in standard input devices like a keypad or a mouse (1.2 × 1.2 × 1.5 cm L × W × H). (b) Diagram of the proximity sensor and high voltage pin configuration (side view). The diagram is not to scale.

Figure 2-a shows the device we built. This button-sized finger sensing device consists of one infrared proximity sensor and one vertical pin (see Figure 2-b). The sensor configuration is similar to other proximity sensing devices (e.g., [8, 12, 34]). However, the pin adjacent to the sensor is connected to a high voltage resonant transformer to emit electric arcs. The arcs pass from the pin through the tiny aperture in the surface to stimulate the fingertip above the surface. With this new configuration the device can detect hover and give users in-air feedback up to 6 mm in height (see Figure 1).

Example scenarios

Our prototype can stimulate the fingertip with electric arcs above a finger-sensing device (see Figure 1). This combination of proximity sensing with in-air feedback provides a new way to facilitate the input of hover gestures, for example, for preview-able interfaces and for interacting with content displayed on a monitor [31]. In particular, SPARKLE can confirm that an interaction is taking place when manipulating virtual content (e.g., object selection) [7, 31] and guide the finger movements to position and maintain the hover distance during the interaction [7, 38]. Different feedback sensations can signal which hover gestures the user is performing, or they can represent state transitions (e.g., to emulate pressing a mouse button [29]). Moreover, when combined with a display, SPARKLE can make the interaction with virtual objects more engaging and realistic, for example, by warning the user before executing a risky action, or by providing the feeling of the properties of simulated objects (see Figure 3).

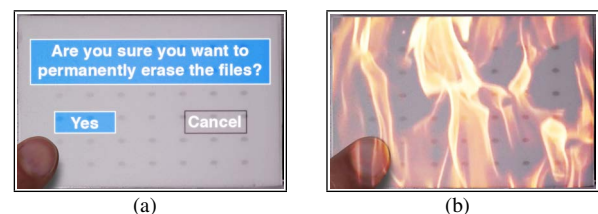

Figure 3. Example scenarios visualized with top-projection on a touchpad-sized surface: (a) In-air tactile feedback can warn the user before pressing the “Yes” button. (b) Thermal feedback can make playing games more realistic (e.g., feeling the heat of fire or explosions).

OPERATING PRINCIPLE

SPARKLE uses a high voltage resonant transformer to create electric arcs. Figure 4 shows the key hardware components and Figure 6-a the system configuration. In this section, we

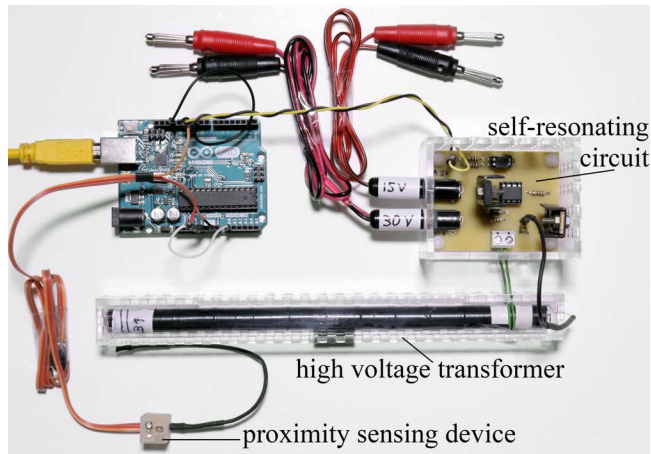

Figure 4. Sparkle's key components.

describe the operating principle, the design of the transformer and driver circuit, and the method we use to create touchable electric arcs with various strength and time span.

Resonant transformer

A resonant transformer consists of two magnetically coupled coils wound on the same core. The transformer works through electromagnetic induction. When an alternating current flows through the primary winding, it generates a changing magnetic field that induces an alternating current in the secondary winding. The resonant frequencies of the primary and secondary coils are matched with tuning capacitors to transmit power efficiently. The driving circuit then operates at the tuned resonant frequency. Here we do not use tuning capacitors. We employ a self-resonating circuit to drive the transformer at its coupled resonant frequency.

Resonant frequency

Besides the design of the transformer coils (e.g., core material, length, diameter, number of turns), the load capacitance determines the resonant frequency and the time constant of the circuit, which is the amount of time it takes for the voltage and current to change from their initial to their final values. The load capacitance changes when the human body or other conductive objects capacitively couple to the coils. This change happens when the user moves his finger closer to the output electrode and when the user interacts with the arcs (see Figure 5). However, the performance of the transformer degrades when the coils do not operate at resonant frequency. For this reason, we use a self-tuning circuit as manual tuning during operation is impracticable for interactive scenarios.

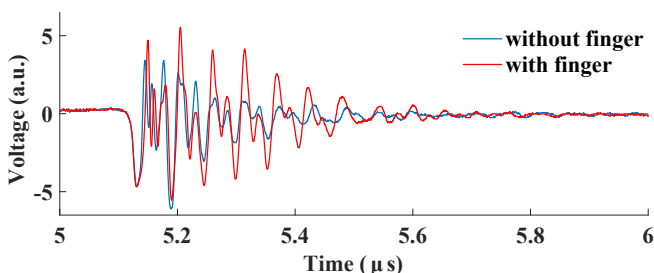

Figure 5. The proximity of the finger adds load capacitance.

Self-resonating circuit

The self-resonating (self-tuning) circuit automatically drives the coil at its natural frequency. The circuit we developed is based on a slayer exciter (see Figure 6-b), a variant of a blocking oscillator that produces a free-running signal. This circuit enables peak performance during regular operation whenever the resonant frequency changes. The circuit works as follows:

The 10k (pull-up) resistor forward-biases the driver and the MOSFET M1 (a type of transistor), and switches them to ON state. This state initiates a current flow at the collector of M1 through the primary winding L1 of the transformer, which induces a voltage in the secondary winding L2. L1 and L2 are wound 180° out-of-phase (see phasing dots), which makes the induced voltage at the bottom end of L2 to increase positively. Because the bottom end of L2 is connected to the base of the MOSFET driver, the base-voltage increases and drives M1 towards saturation. The circuit behaves like an RLC-circuit, and the current in L1 and the voltage in L2 develop according to their total time constant. In an RLC-circuit, the rate of change of current decreases towards saturation. As a result, the rate of change of current in L1 decreases, and the voltage at the bottom end of L1 decreases towards zero. This decrease in the voltage applied at the base of the MOSFET driver drives M1 towards OFF state. As a result, the collector current or current in L1 decreases towards zero. In this process, however, due to RLC-circuit behavior, the rate of change of current in L1 increases, and the voltage at L2 swings back to increase. This increase leads to an oscillation by repeating the above mentioned process that is determined by the RLC-circuit, or self-tuned by the resonant frequency of the coil.

High voltage electric discharges

We use a step-up transformer to boost the voltage from a few volts to several kilovolts, and decrease the current at the output electrode at the secondary winding L2. The self-resonating circuit drives the transformer with a current limited DC supply connected to the primary winding L1 (see Figure 6-a,b). The alternating current resulting in the secondary winding L2 decreases with the turns ratio, while the voltage increases with the ratio. When the electric field strength approaches the dielectric strength of air (≈ 3 kV/mm), the molecules in the air around the output electrode get ionized and create a conductive region of plasma (i.e., corona discharge). When an external conductive object is brought closer to the electrode, the ions and electrons move freely between them due to the electric field, and create a visible electric arc.

Creating safe and touchable electric arcs

Stimulating the human body with electricity can be dangerous. The IEEE recommends a maximum AC current of 2 mA root mean square (rms) when the voltage exceeds 1 kV rms [28]. The stored energy should not exceed 10 mJ. These levels are slightly below the startle response threshold. The hardware we built complies with these rules. The transformer does not store energy, and the circuit does not use a capacitor to cause electric shocks from static electricity. In addition, we use a current-limited DC supply to limit the output current. Finally, we switch the transformer with pulse width modulation to control the power of the arcs, which modulates

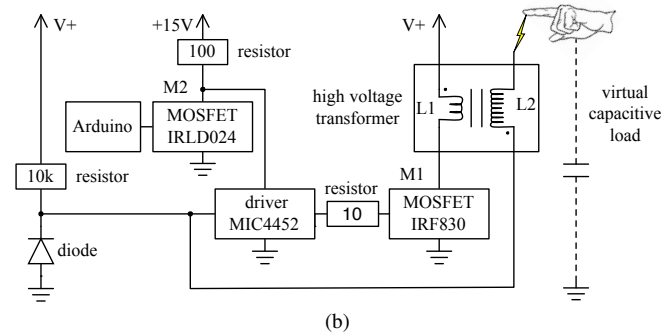
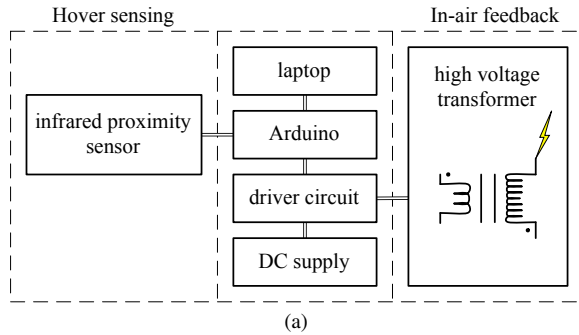

Figure 6. Sparkle creates touchable electric arcs for hover feedback: (a) system diagram; (b) details of the self-resonating circuit.

the discharge down to low frequencies and duty cycles (see Figure 6-b M2 and Figure 13). The same technique is applied in other domains to limit the power of a device, for example, to control the ultrasound intensity in clinical applications [1] or to drive a motor with pulse width modulation [3].

With these precautions, we reduced the discharge to a maximum current of 0.21 mA rms for the electric arcs used in our study. This current magnitude is safe to touch for high voltages [28]. A natural mild static shock has similar voltage and energy. Other human computer interaction applications use lower voltages but transmit higher currents into the body (e.g., 600 V, 10–40 mA for electrotactile stimulation [2], and 33 V, 100 mA for electrical muscle stimulation [37]).

Transformer coil

We use a low-loss soft ferrite core (Ferroxcube ROD10/200-4B1, 20 cm length, 1 cm in diameter). The ferrite increases the magnetic coupling and transfers more energy from the primary to the secondary winding than an air core. We use insulated copper wire for the primary winding (22 AWG) and enamelled copper wire for the secondary winding (32 AWG) with a turns ratio of 425 (2:850, secondary winding 16 ohm, 30.6 mH, 450 kHz resonant frequency). We chose two turns for the primary winding to maximize the output voltage and to minimize the current. The secondary winding is insulated from the core with teflon tape and with electrical tape from the primary winding.

The position of the primary winding L1 around the secondary winding L2 affects the output voltage and current. To find the position where the arcs have maximal length, we measured the output voltage with a voltage divider connected to the output electrode (7.8 MΩ, 0.01 Ω). Figure 7 shows the effect of

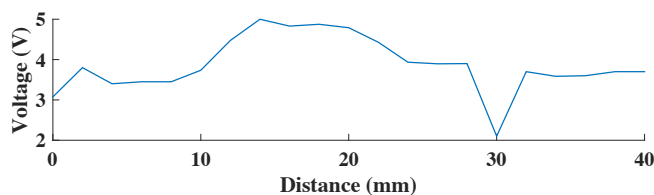

Figure 7. The output voltage is maximal when the primary winding is positioned 14 mm upwards from the bottom of the rod. The dip at 30 mm is probably caused by a defect in the secondary winding.

the position of the primary winding on the output voltage of the high voltage transformer.

Figure 8 shows the output of the transformer. The self-tuning driver circuit exhibits pulsed high frequency operation. The transformer is a highly underdamped system with quality factor $Q = 31.5$, measured at 100 kHz at the primary coil with the secondary coil in open-circuit. The corresponding peak overshoot is 95.1%, which indicates a large peak output voltage. This peak is advantageous to our application to create long electric arcs. With 30 V peak input voltage (current limit 1.4 A) and turns ratio of 425, the peak output voltage is expected to be 12.75 kV. The breakdown electric field strength of dry air (3 kV/mm) indicates an arc length of 4.25 mm. Due to overshoot in the circuit and the influence of electrode geometry a larger voltage is created. These factors allowed us to regularly obtain visible electric arcs 6 mm in length, which can be felt higher (approximately 1 cm) depending on the modulation frequency and duty cycle. Longer arcs (e.g., 2–3 cm) are possible by increasing the input voltage or turns ratio. However, long arcs need further exploration because they can have an uncertain discharge path, which can make the interaction with the finger and the sensation less predictable.

Grounding

Unlike other technologies that inject electrical signals into the user’s body [5] or that charge the user [26], SPARKLE does not equip users with a signal generator or with a high-voltage DC charger. Users do not need to be directly linked to ground [5, 26], nor charged and discharged [26] to perceive a sensation. The resonant transformer induces alternating current and voltage. The electric arcs consist of charged particles with approximately equal numbers of electrons and positively charged ions, which in essence charge or discharge the user consecutively during the interaction.

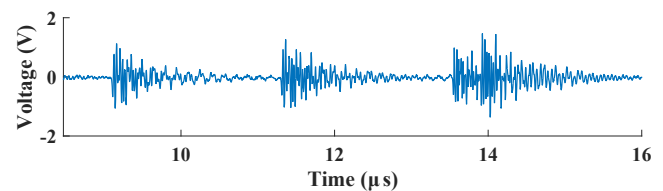

Figure 8. The output voltage of the resonant transformer (450 kHz).

EM/RF shielding

The transformer emits radio-frequency (RF) electromagnetic (EM) radiation. The EM radiation has a narrow band due to resonant operation. Nevertheless, this radiation can interfere with nearby electronic components and devices that lack an electromagnetic shield. To reduce interference the devices and components can be shielded with EM/RF absorbers and coatings, or with IC packages with EM shields. Alternatively, the transformer can be shielded. Because the frequency of operation is above 100 kHz, a Faraday cage made from a wire mesh or metal plate can sufficiently shield the equipment. Below 100 kHz, a magnetic shield made from Permalloy or Mu-metal is useful. Alternatively, the transformer can be placed inside a feed-through capacitor to shield EM/RF radiation. The feed-through capacitor configuration can be an enclosure made from nested metal plates connected to make effectively a two-plate capacitor, with one plate connected to the ground potential and the other kept at the floating state. However, this configuration will add capacitance to the resonant circuit, and affect its frequency and voltage output.

ELECTRODE DESIGN

The strength of the electric field dictates the length of the electric arcs. The shape and size of the electrodes dictate the electric field emanating from them. Choosing the right electrodes is critical for effective implementation of SPARKLE as the geometry affects the length and strength of the arcs, as well as scaling of the devices. First, we present different electrode designs that we experimented with for our implementation. Then, we discuss various scaling techniques to build from a button-sized device to a touchpad-sized surface and assess candidate technologies for proximity sensing.

Pins



Figure 9. We use DIP socket pins to emit the electric arcs.

The electric fields from curved surfaces can be highly nonlinear with high field gradients or voltages. The high voltages cause the breakdown of molecules in air and the electric discharge that becomes visible as an arc. Pins have a high curvature at their tips and were our first choice to create electric arcs. We explored pins of various shapes and sizes. Paper pins and needles have highly curved tips, but they are difficult to integrate into electronic circuits. For our prototype we chose the solder pin tails from a standard dual-in-line (DIP) IC socket (see Figure 9), which can be easily integrated into a printed circuit board to build SPARKLE devices. These pins are thin (0.6 mm × 0.15 mm), pointy, and can be sharpened. We used the clean undamaged pins without extra treatment.

Our button-sized device contains one pin adjacent to an infrared proximity sensor (see Figure 2). The sensor and the pin are separated by 5 mm on the circuit board. The base of the pin is sealed with glue to avoid arcing to the solder connections of the sensor and to minimize corona discharge.

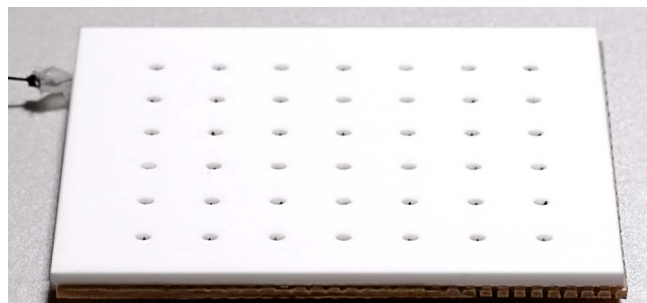

Figure 10. Our larger prototype consists of 42 pins used as high voltage electrodes, arranged under a touchpad-sized surface (6 × 4 cm).

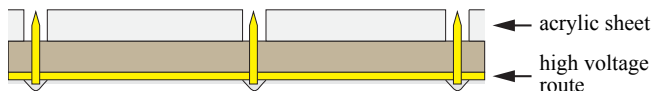

Figure 11. Diagram of high voltage pins on the circuit board. The high voltage route is sealed with hot glue. The diagram is not to scale.

To assess whether SPARKLE can be scaled up to a larger surface, we built three prototypes with form factor similar to a touchpad. The first prototype contains 6 × 7 pins connected in series with a distance of 7.62 mm between adjacent pins (see Figure 10 and Figure 11). The pins are plugged into a perforated acrylic sheet (3 mm thick). Similar to our button-sized device the pins can be integrated between multiple infrared sensors into a proximity sensing touchpad [8, 12].

With multiple pins the transformer emits 2 mm long electric arcs (see Figure 12-a). The short length of the arcs is caused by additional corona discharge before dielectric breakdown from each pin and by the higher capacitance of the pins, which holds the charge and increases the power requirements of the transformer to emit the arcs. Corona discharge can be minimized by grouping smaller sets of pins that are switched individually (e.g., using active matrix addressing with relay switches), which can also enable multi-finger feedback.

Wire mesh and transparent electrodes

Our second and third touchpad prototypes consist of one transparent electrode (without holes) and one fine wire mesh (see Figure 12-b,c). At first sight these flat electrodes seem to provide ideal conditions to instrument a large surface with in-air feedback. However, certain limitations of these electrodes need to be addressed. The electric field from a thin wire can be nonlinear with a high field gradient similar to a pin. By contrast, the electric field from a flat surface is not very nonlinear and has a lower field gradient compared to the pointy tip of a pin. The lower electric field gradient reduces the electric discharge. Also, the large surface areas of

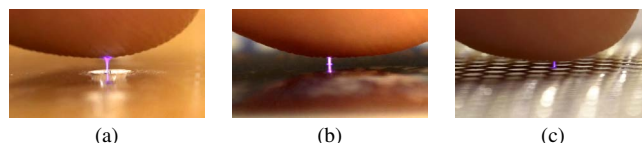

Figure 12. Electric arcs emitted to the fingerpad from (a) the array of 42 pins, (b) a transparent electrode, and (c) a wire mesh.

the wire mesh and the transparent electrode are exposed to air, from which charge leaks through corona discharge. The wire mesh leaks more charge than the transparent electrode because of its larger exposed area and introduces more parasitic capacitance, which increases the power requirements of the transformer. We found that a transparent electrode produced longer arcs than a wire mesh of similar size. Being transparent and devoid of hole, this electrode is better suited for scaling SPARKLE to a touchpad-sized surface.

We used one transparent electrode coated with a thin layer of Indium tin oxide, on which surface the electric discharge takes place. However, a thin coating can evaporate with time under high voltage discharges. Electrodes with a thick coating can be used to implement SPARKLE for durable operation, but they can limit the visibility in applications that need a high degree of surface transparency. Future thin-film electrodes can be made of other nanoparticles, nanowires or graphene, but it is unclear if these materials are durable to withstand continual exposure to electric arcs. Thin-film electrodes are preferred because the standard flat plate electrodes produce shorter arcs due to their high capacitance. In the future, patterned transparent electrodes and wire meshes with coating can be considered to reduce corona discharge.

Instrumentation for a mobile or portable device

Shorter coils, less than 200 mm in length that we used, are needed to implement SPARKLE in mobile devices. Thinner magnet wire can be used to wind secondary coils with more than 800 turns, which are needed to generate high voltages. Because the current in the secondary coil is low (< 2 mA rms), very thin magnet wires can be used. For example, with 40 AWG wire (13.7 mA maximum current for power transfer) a secondary coil less than 70 mm in length can be wound (including 10% winding error).

Because of resonant oscillatory operation, the driving circuit necessitates a high current rating MOSFET. However, the current swing is due to the high reactive power in the LC-circuit. The power loss in the ferrite core is due to hysteresis, eddy current and residual losses, which is minimized by choosing a material with minimal loss factor in the frequency of operation. With a maximum safe current of 2 mA rms and 16 Ω resistance in our coil, the power loss is approximately 64 μ W. However, with 30.6 mH inductance the reactive power required at 450 kHz is 346 mW. Therefore, a power supply circuit capable of sustaining high current oscillation is needed to implement SPARKLE in a mobile device. In addition, the transformer needs to be shielded (see EM/RF shielding).

Instrumentation for a display

We see the possibility to combine SPARKLE with displays. For example, the touchpad-sized prototype can be turned into a top-projected display using a diffuser surface perforated at the location of the pins [14]. Alternatively, transparent electrodes can be placed on a diffuser surface for rear-projection [23], or on an LCD. The transparent thin film polymer (0.18 mm) insulates the electrode coating (100 nm) from the LCD and minimizes the EM/RF interference with the pixels.

Proximity input

Infrared sensors

For the button-sized device (see Figure 2) we use one infrared emitter and receiver (Kingbright L-934F3C and L-93DP3C, 940 nm, 3 mm in diameter) to sense finger proximity from the amount of light reflected from the skin. For the touchpad-sized prototype (see Figure 10) the high voltage pins can be arranged between surface-mount infrared sensors under a transparent sheet [8, 12]. Other solutions are stacked infrared light planes [15, 24, 36] or depth-sensing cameras [40, 41].

Electric field and capacitive sensing

Alternative methods to sense finger proximity are electric field [44] and capacitive sensing [7, 29, 31, 32], which measure the changes in capacitance induced by the human body to detect touch and hover. The self-resonating circuit we developed can be used as basis for proximity sensing (see Figure 5). The resonant frequency of the transformer depends on the virtual capacitance that the secondary coil couples with its surrounding (see Figure 6-b). The position of the finger with respect to the coil modulates this capacitance. In addition, the electric discharge from the high voltage electrode depends on the surrounding. When the finger approaches the electrode, the load impedance at the transformer output is modulated, which also affects the resonant frequency. Thus, the voltage or current in the driving circuit can be monitored to sense finger proximity. However, sensing the change in capacitance is difficult due to the electric discharge, which has a large and unreliable current flow. Apart from the uncertain path followed by the arc, the skin type, the condition and orientation of the finger can also affect the measurement. On tabletops (e.g., SmartSkin [29]) multiple pins can be arranged between the capacitive sensing elements, but the sensing and actuation phases need time multiplexing to avoid interference.

CONTROL PARAMETERS FOR ELECTRIC ARCS

In a controlled environment SPARKLE can create mild electric arcs of several kilovolts that open up a new design space of tactile and thermal sensations for hovering. As this technique has not yet been used for in-air feedback, we started by looking into some of the parameters that we can control with our hardware to make the arcs harmless and touchable.

The mechanism of stimulation with electric arcs is similar to electrostatic feedback for which electric current is directly transmitted into the skin to stimulate the nerves [17, 18]. The main parameters used for controlling electrostatic sensations are current magnitude and pulse frequency [2], and polarity of the electrode [18]. To create sensations from body-carried electrostatic charge only the voltage can be controlled to change the intensity of the electric shock [26].

Unlike electrostatic feedback, electric arcs are plasma created by ionizing air. The plasma consists of charged particles and electrons that can enter the skin to stimulate the nerves. In addition, the temperature of plasma is very high. However, by limiting the exposure duration and by controlling the distance to the finger the plasma can contribute to creating warm or hot sensations without damaging the skin.

SPARKLE offers several parameters to change the electrical characteristics of the arcs. The turns ratio and the DC supply voltage provide a means to control the length of the arcs, which corresponds to the rms voltage output of the transformer. The supply current determines the current induced in the transformer and the electric charge. However, the turns ratio is fixed in our setup, and our driver circuit does not allow us to programmatically control the voltage and the current.

Here we use an infrared proximity sensor to trigger the arcs when the finger hovers above the surface, and we control the modulation frequency and the duty cycle to alter the sensations at the fingertip. We modulate the electric discharge from resonant frequency (see Figure 8) down to a frequency detectable by the receptors in the fingertip and set the duty cycle to limit the time that the arcs affect the skin (see Figure 13).

EVALUATION

As a first step to find arcs that are usable for hover input we probe and chart the design space of sensations. Our aim is to find example stimuli and to characterize the sensations they evoke. The study was approved by the university's research ethics committee to ensure the safety of the participants.

Pilot test

We conducted the first informal study together with one colleague. We experimented with arcs of low duty cycles and different modulation frequencies in continuous operation (e.g., 200 Hz, 1%), which we slowly touched with the pad of the index finger. Admittedly, during this playful test the arcs were either imperceptible, tingling or prickling, or too hot, sometimes scorching the skin in a tiny point. To find the range of values for which the arcs did not damage the skin with our transformer setup, we swept through combinations of frequencies and duty cycles with short pulse durations (e.g., 50–2000 ms) or with continuous output.

For continuous output the arcs were on independent of the height of the finger. These arcs felt warmer or hotter at low frequencies than at high frequencies for the same duty cycle (e.g., 10–1000 Hz, 5–10%), which can be explained by the time period during which the arcs were on. Tingling and prickling sensations occurred mostly when the finger was just above the tip of the arcs, which allowed us to touch the arcs for several seconds without perceiving discomfort. For shorter distances, however, the same arcs felt hot or painful.

For the short pulse durations the button-sized proximity sensor triggered the arcs when the finger was approximately 3 mm above the device. These arcs created a warm sensation

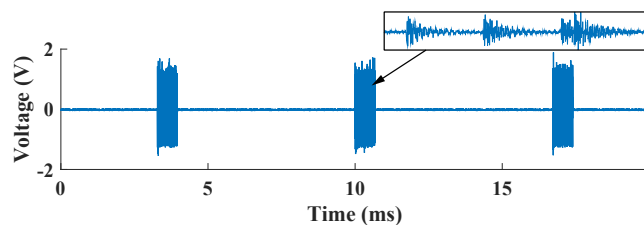

Figure 13. In this example the output voltage is down-modulated from resonant frequency (inset) to 150 Hz with 10% duty cycle.

or a pricking after-sensation (e.g., 350 Hz, 60%, 200 ms), which felt more intense for higher duty cycles or when the finger was very close to the device. The sensations from arcs with longer pulse durations (e.g., 1–2 sec) resembled those created with arcs emitted continuously.

This informal exploration also demonstrated our strongly subjective ratings and a poor repeatability of the sensations. We tended to rate the sensations differently, for example, as imperceptible or as subtle, as warm or as hot, depending on the height and contact point on the finger, the exposure duration, and skin characteristics. This large variation strongly suggests that many different sensations can be perceived, yet they can be difficult to control and to reproduce because several parameters can affect the sensations.

User study on sensations created from mild electric arcs

We conducted this study to explore in more detail the sensations that the arcs can elicit. Based on our assessment of the arcs we selected five stimuli with a short and with a continuous exposure duration to identify the vocabulary used by the participants to verbalize their experiences. The study followed a within-participants design with three factors:

- STIMULUS = {S1, S2, S3, S4, S5} (see Table 1);
- NOISE = {without, with} noise played loud in the room;
- FINGER = {index, middle} of the dominant hand;

We used white noise to cancel out the audio cues created by the modulation frequency of the arcs.

Stimulus	F (Hz)	D (%)	T (ms)	P (W)	E (J)
S1	580	58	continuous	2.6	
S2	130	11	continuous	1.1	
S3	150	10	continuous	1.0	
S4	100	50	300	2.2	0.7
S5	300	60	200	2.7	0.5

Table 1. The stimulus characteristics with estimated power and energy (the frequency and duty cycle for S1 and S2 were calculated post hoc from experimentally measured data).

Participants

Twelve volunteers participated (three women), age 22–42 years old (average 28.9, median 29.5). None of them had previously touched electric arcs. Two participants had previously experienced tactile feedback from an electro-tactile device.

Apparatus

We used the button-sized device to emit the electric arcs. The software for sensing finger proximity and for activating the transformer was implemented on OS X and Arduino Uno.

Procedure

The experimenter first informed the participants about the hardware and the goal of the study. He activated the system and touched the arcs to demonstrate their safety. After this introduction the participants signed the consent form.

The participants sat in a chair. The experimenter instructed them to use their dominant hand and to alternately explore

the arcs with the pad of their index and middle finger. He explicitly instructed them to slowly approach the proximity sensing device in direction to the sensor and not to touch the casing in order to avoid perceiving other tactile sensations.

The presentation order of NOISE and STIMULUS was counterbalanced across the participants. The stimuli S1–S3 were continuously on and therefore independent of the height of the finger. The stimuli S4 and S5 were activated when the finger was approximately 3 mm above the device, which the participants re-triggered by raising the finger higher than this threshold distance and then lowering the finger again below this threshold. For each condition we allowed the participants to explore the arcs as long as they wished to be able to interpret the sensations. The study lasted approximately one hour.

Data collected

The participants filled out a questionnaire to describe the sensations. For each condition they first verbalized the sensations in their own words. Then, they selected from a list nouns that best described the sensations. We chose nouns based on known descriptions of electrical stimuli (e.g., tingling, prickling, warm, and hot [9, 10, 17, 18]). Finally, they rated the characteristics of the arcs on a 5-point Likert scale (perceptibility, intensity, comfort, pain, and stress to touch the arcs).

RESULTS AND DISCUSSION

Table 2 summarizes the nouns the participants chose for the stimuli and illustrates the different qualities of the sensations. In their own words S1 was the “strongest stimulus”, “hot”, “burning”, “stinging”, “like a needle”, or “like touching a sharp object”. However, they also stated: “the temperature is pointy, localized in a tiny point [...] longer burning does not matter since it’s localized, there is no harm and won’t be hot for a limited duration”, “not too hot”, and “finally a clear one!”. S2 created similar sensations described as “sharp”, “like a needle”, or “piercing”, but “weaker”. S3 was a “warm vibration in a tiny point”, “tickling and warm”, and “warmer after several seconds” without pain. One participant compared S3 to “a stick I could touch from different sides”.

The short pulse S4 felt like a “warm tingling vibration”, a “weak needle”, or a “small feather touching my finger”. However, some participants stated that they perceived this arc well only in some spots on the fingerpad. Similarly, the brief pulse S5 was a “localized point of warmth”, like “air from a nozzle” or “touching an object”, but also “sharp heat but small”, “like a needle [...] more explicit and obvious”.

In general, all stimuli were accompanied with thermal sensations, but warmth was least noticeable for S3, unless the finger was in contact with the arcs for a longer duration. For the continuous arcs S1 and S2 two participants explained they were able to perceive vibration or touch sensations without warmth when they held the finger high enough above the arcs.

One participant commented that the sensations were tiny and localized compared to other technologies that stimulate the whole pad of the finger. In general, the brief stimuli S4 and S5 were perceived as more localized than the continuous stimuli S1–S3. For the continuous arcs the participants also experienced spread sensations, which could have been caused by

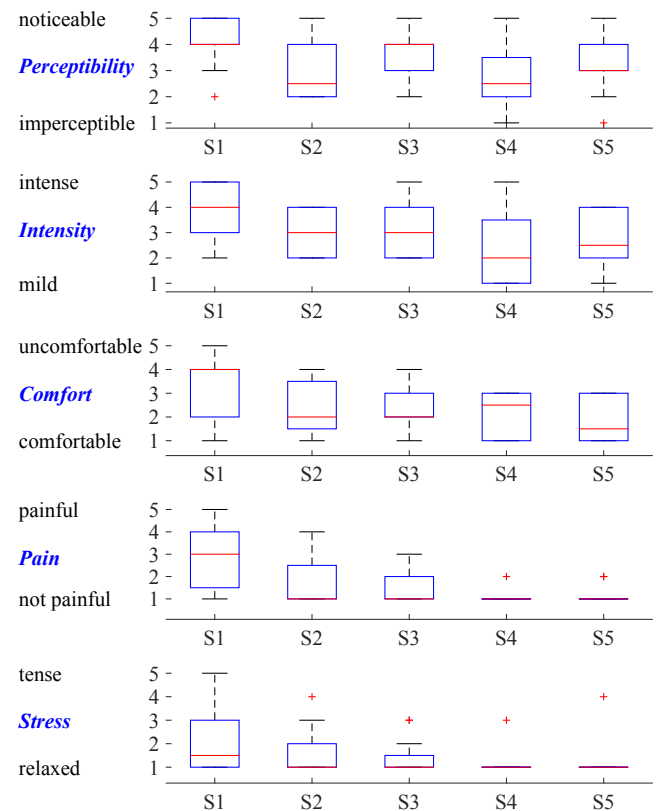

Figure 14. Ratings of perceptibility, intensity, comfort, pain and stress to touch the arcs with the index finger when hearing the sound of the arcs.

finger tremor. We also observed that the arcs could spread away from the pin and affect a larger skin area (1–2 mm).

Figure 14 shows the participants’ ratings. The dimensions *Pain* and *Stress* show a gradual decrease from S1 to S5, which confirms that S1 is the most pronounced stimulus. The stimuli S2 and S3, and the non-continuous S4 and S5 did not cause pain or stress and were perceived with nearly similar intensity, suggesting that S4 and S5 can be used as feedback for a simple hover gesture. One participant, however, consistently lowered his finger very close to the device where the arcs are more powerful. At the end of the study, he explained having difficulties to hover his finger, which is why he perceived some pain and felt stressed to touch the arcs.

A repeated measures ANOVA with the aligned rank transform [43] and post-hoc t-tests with Bonferroni correction supports the participants’ descriptions of S1. STIMULUS has a significant main effect on *Perceptibility* ($F_{4,44} = 8.18, p < .01$), confirming that S1 is more noticeable than S2 ($p = .009$), S4 ($p = .011$), and S5 ($p = .039$). The main effect on *Intensity* ($F_{4,44} = 8.93, p < .01$) and *Pain* ($F_{4,44} = 12.08, p < .01$) is significant, confirming that S1 feels more intense ($p < .01$) and painful than S2–S5 ($p < .01$). The main effect on *Stress* ($F_{4,44} = .007, p < .01$) and *Comfort* ($F_{4,44} = 8.83, p = .036$) is significant (post-hoc t-tests are not significant).

The effect of NOISE on *Intensity* is significant ($F_{4,44} = 8.10, p < .016$). The stimuli were perceived as more intense when listening to white noise than when hearing the sound of

Stimulus	Tactile properties			Sharpness		Temperature		Contact point	
S1	rough (50)	vibration (58.3)	touch (33.3)	tickle (25)	pain (33.3)	warm (50)	hot (50)	localized (50)	spread (50)
S2	rough (33.3)	vibration (50)	touch (41.7)	tickle (41.7)	sting (33.3)	warm (75)	hot (25)	localized (58.3)	spread (41.7)
S3	rough (41.7)	vibration (50)	press (33.3)	tickle (33.3)	tingle (41.7)	warm (75)		localized (33.3)	spread (66.7)
S4	smooth (41.7)	vibration (33.3)	touch (33.3)	tickle (33.3)		warm (58.3)		localized (58.3)	
S5		vibration (50)	touch (33.3)	tickle (41.7)	tingle (33.3)	warm (41.7)		localized (75)	

Table 2. The most frequent nouns (in %) the twelve participants associated with the sensations at the index finger when hearing the sound of the arcs.

the arcs. Two participants noted that the arcs felt more painful when they did not expect them to occur, or when they lowered their fingers very close to the device (“I did not hear the electricity”). Yet one participant considered the unexpected sensations as “surprising and nice”. In contrast, three participants explained they felt more tense to hear the sound created by the arcs, which made them touch the arcs more carefully (“I feel more stressed”, “I hesitate more to get closer to the device”, “I feel more afraid to touch [...] I want to stay away from electricity”, “with the sound I tend to approach less my finger [to the device], then it’s a bit weaker”). Other participants explained that the sound gives a hint when the arcs start and helps them to find the right position where the touch is well noticeable and not too hot (“the sound influences a lot”, “easier to notice due to the sound”, “the sound is fun”, “more enjoyable”). These comments explain the lower intensity of the sensations when hearing the sound of the arcs.

The effect of FINGER is not significant for neither dimension. While some participants perceived the same or very similar sensations with both fingers, others considered either their index or middle finger as less sensitive, which could vary with the experimental conditions. These results are not surprising as the sensations experienced from electricity depend on the contact point and the characteristics of the skin (e.g., thickness, intact or damaged [9, 10, 17]). Two participants did not perceive the stimuli S3, S4, and S5 during all experimental conditions, whereas others noticed a sensation only when they moved their fingers very close to the device.

These findings confirm that SPARKLE can create touchable arcs that can give users in-air feedback for a simple hover gesture. Although the arcs may appear to be scary to touch at first, the participants quickly got used to interacting with the arcs, which suggests that experience can help overcome the initial anxiety and remove concerns about the safety of this technology. Moreover, the participants often considered our selection of arcs as subtle and weak, which suggests the possibility to design stronger sensations.

The participants perceived sensations with different qualities depending on the experimental conditions. However, the sensations can also depend on previous experience and training, the contact location, and the condition and characteristics of the skin. Previous work showed that these factors can affect electrical stimulation [9, 10] and feedback from electrotactile devices [17]. Individual perception differences also exist for temperature [42] and pain, suggesting that sensations associated with electric arcs can be difficult to generalize.

Our observations and the participants’ comments suggest that the length of the arcs is a key factor in creating sensations that

are perceived, for example, as tingling, warm, or hot. The threshold between these sensations is narrow. To control the arcs so that users perceive these sensations more uniformly necessitates controlling the parameters that affect the characteristics of the arcs, for example, by controlling the input voltage and current dynamically to adjust the length and the power of the arcs depending on the hover height. Sensing the input finger and its orientation (e.g., with additional proximity sensors) can further help to control the sensations.

LIMITATIONS AND FUTURE WORK

SPARKLE is subject to several limitations. First, our system configuration emits relatively short electric arcs, which restricts the hover range for in-air feedback. Higher input voltages or turns ratios can increase the length of the arcs. However, the power requirements of the system depend on the design of the high voltage transformer and of the electrode, which need to be tailored to the application scenario.

Another restriction is the size of the high voltage transformer. While a large transformer can be installed, for example, in a desktop environment, it is not suitable for mobile devices. Likewise, scaling up the discharge electrode to instrument a touchpad-sized surface increases the corona discharge and the power requirements. One candidate solution to scale SPARKLE to a larger form factor is to use multiple pins. For future work, we plan to experiment with switching individual pins to reduce the corona discharge and to explore solutions for implementing multi-finger feedback.

Finally, while our initial exploration of the design space of in-air feedback with electric arcs shows that users can perceive different tactile and thermal sensations for a simple hover gesture, the sensations can vary between users and can be difficult to reproduce. Further studies on the parameters that can affect the characteristics of the arcs are needed to create controllable and repeatable sensations at the fingertip.

CONCLUSION

We introduced touchable electric arcs to stimulate the fingertip in air with tactile and thermal sensations. We explored the design space of the technology and provided guidelines for controlling and integrating electric arcs into a hover sensing device. In a user study we tested example stimuli and identified tingling, warm, and hot sensations that users perceived when hovering. We hope that SPARKLE will inspire more researchers to explore this new technology and develop exciting applications with hover feedback.

ACKNOWLEDGMENTS

This work was funded in part by the ERC (Proof of Concept GA640749).

REFERENCES

1. Advisory Group on Non-ionising radiation. 2010. *Health Effects of Exposure to Ultrasound and Infrasound (RCE-14)*. UK Health Protection Agency. Retrieved September 21, 2016 from https://www.gov.uk/government/uploads/system/uploads/attachment_data/file/335014/RCE-14_for_web_with_security.pdf.
2. M. Ercan Altinsoy and Sebastian Merchel. 2012. Electrotactile feedback for handheld devices with touch screen and simulation of roughness. *IEEE Transactions on Haptics* 5, 1 (2012), 6–13. DOI : <http://dx.doi.org/10.1109/TOH.2011.56>
3. Michael Barr. 2001. Pulse Width Modulation. *Embedded Systems Programming* (2001), 103–104.
4. Olivier Bau, Ivan Poupyrev, Ali Israr, and Chris Harrison. 2010. TeslaTouch: Electro-vibration for Touch Surfaces. In *Proceedings of the 23Nd Annual ACM Symposium on User Interface Software and Technology (UIST '10)*. ACM, New York, NY, USA, 283–292. DOI : <http://dx.doi.org/10.1145/1866029.1866074>
5. Olivier Bau, Ivan Poupyrev, Mathieu Le Goc, Laureline Galliot, and Matthew Glisson. 2012. REVEL: Tactile Feedback Technology for Augmented Reality. In *ACM SIGGRAPH 2012 Emerging Technologies (SIGGRAPH '12)*. ACM, New York, NY, USA, Article 17, 1 pages. DOI : <http://dx.doi.org/10.1145/2343456.2343473>
6. Tom Carter, Sue Ann Seah, Benjamin Long, Bruce Drinkwater, and Sriram Subramanian. 2013. UltraHaptics: Multi-point Mid-air Haptic Feedback for Touch Surfaces. In *Proceedings of the 26th Annual ACM Symposium on User Interface Software and Technology (UIST '13)*. ACM, New York, NY, USA, 505–514. DOI : <http://dx.doi.org/10.1145/2501988.2502018>
7. Xiang 'Anthony' Chen, Julia Schwarz, Chris Harrison, Jennifer Mankoff, and Scott E. Hudson. 2014. Air+Touch: Interweaving Touch & In-air Gestures. In *Proceedings of the 27th Annual ACM Symposium on User Interface Software and Technology (UIST '14)*. ACM, New York, NY, USA, 519–525. DOI : <http://dx.doi.org/10.1145/2642918.2647392>
8. Sangwon Choi, Jaehyun Han, Sunjun Kim, Seongkook Heo, and Geehyuk Lee. 2011. ThickPad: A Hover-tracking Touchpad for a Laptop. In *Proceedings of the 24th Annual ACM Symposium Adjunct on User Interface Software and Technology (UIST '11 Adjunct)*. ACM, New York, NY, USA, 15–16. DOI : <http://dx.doi.org/10.1145/2046396.2046405>
9. Charles F. Dalziel and Thomas H. Mansfield. 1950a. Effect of frequency on perception currents. *American Institute of Electrical Engineers, Transactions of the* 69, 2 (1950), 1162–1168. DOI : <http://dx.doi.org/10.1109/T-AIEE.1950.5060274>
10. Charles F. Dalziel and Thomas H. Mansfield. 1950b. Perception of electric currents. *Electrical Engineering* 69, 9 (1950), 794–800. DOI : <http://dx.doi.org/10.1109/EE.1950.6434052>
11. Euan Freeman, Stephen Brewster, and Vuokko Lantz. 2014. Tactile Feedback for Above-Device Gesture Interfaces: Adding Touch to Touchless Interactions. In *Proceedings of the 16th International Conference on Multimodal Interaction (ICMI '14)*. ACM, New York, NY, USA, 419–426. DOI : <http://dx.doi.org/10.1145/2663204.2663280>
12. Jiseong Gu, Seongkook Heo, Jaehyun Han, Sunjun Kim, and Geehyuk Lee. 2013. LongPad: A Touchpad Using the Entire Area Below the Keyboard of a Laptop Computer. In *Proceedings of the SIGCHI Conference on Human Factors in Computing Systems (CHI '13)*. ACM, New York, NY, USA, 1421–1430. DOI : <http://dx.doi.org/10.1145/2470654.2466188>
13. Sidhant Gupta, Dan Morris, Shwetak N. Patel, and Desney Tan. 2013. AirWave: Non-contact Haptic Feedback Using Air Vortex Rings. In *Proceedings of the 2013 ACM International Joint Conference on Pervasive and Ubiquitous Computing (UbiComp '13)*. ACM, New York, NY, USA, 419–428. DOI : <http://dx.doi.org/10.1145/2493432.2493463>
14. Taku Hachisu and Masaaki Fukumoto. 2014. VacuumTouch: Attractive Force Feedback Interface for Haptic Interactive Surface Using Air Suction. In *Proceedings of the SIGCHI Conference on Human Factors in Computing Systems (CHI '14)*. ACM, New York, NY, USA, 411–420. DOI : <http://dx.doi.org/10.1145/2556288.2557252>
15. Taku Hachisu and Hiroyuki Kajimoto. 2013. HACHISStack: Dual-layer Photo Touch Sensing for Haptic and Auditory Tapping Interaction. In *Proceedings of the SIGCHI Conference on Human Factors in Computing Systems (CHI '13)*. ACM, New York, NY, USA, 1411–1420. DOI : <http://dx.doi.org/10.1145/2470654.2466187>
16. Otmar Hilliges, Shahram Izadi, Andrew D. Wilson, Steve Hodges, Armando Garcia-Mendoza, and Andreas Butz. 2009. Interactions in the Air: Adding Further Depth to Interactive Tabletops. In *Proceedings of the 22Nd Annual ACM Symposium on User Interface Software and Technology (UIST '09)*. ACM, New York, NY, USA, 139–148. DOI : <http://dx.doi.org/10.1145/1622176.1622203>
17. Kurt Kaczmarek, John G. Webster, Paul Bach-y Rita, and Willis J. Tompkins. 1991. Electrotactile and vibrotactile displays for sensory substitution systems. *Biomedical Engineering, IEEE Transactions on* 38, 1 (1991), 1–16. DOI : <http://dx.doi.org/10.1109/10.68204>
18. Hiroyuki Kajimoto, Naoki Kawakami, Susumu Tachi, and Masahiko Inami. 2004. SmartTouch: Electric Skin to Touch the Untouchable. *IEEE Comput. Graph. Appl.* 24, 1 (Jan. 2004), 36–43. DOI : <http://dx.doi.org/10.1109/MCG.2004.1255807>

19. Hojin Lee, Ji-Sun Kim, Seungmoon Choi, Jae-Hoon Jun, Jong-Rak Park, A-Hee Kim, Han-Byeol Oh, Hyung-Sik Kim, and Soon-Cheol Chung. 2015. Mid-air tactile stimulation using laser-induced thermoelastic effects: The first study for indirect radiation. In *World Haptics Conference (WHC '15)*. IEEE, 374–380. DOI : <http://dx.doi.org/10.1109/WHC.2015.7177741>
20. Vincent Levesque, Louise Oram, Karon MacLean, Andy Cockburn, Nicholas D. Marchuk, Dan Johnson, J. Edward Colgate, and Michael A. Peshkin. 2011. Enhancing Physicality in Touch Interaction with Programmable Friction. In *Proceedings of the SIGCHI Conference on Human Factors in Computing Systems (CHI '11)*. ACM, New York, NY, USA, 2481–2490. DOI : <http://dx.doi.org/10.1145/1978942.1979306>
21. Nicolai Marquardt, Ricardo Jota, Saul Greenberg, and Joaquim A. Jorge. 2011. The Continuous Interaction Space: Interaction Techniques Unifying Touch and Gesture on and Above a Digital Surface. In *Proceedings of the 13th IFIP TC 13 International Conference on Human-computer Interaction - Volume Part III (INTERACT'11)*. Springer-Verlag, Berlin, Heidelberg, 461–476. <http://dl.acm.org/citation.cfm?id=2042182.2042224>
22. Ørjan G. Martinsen, Sverre Grimnes, and Hossein Piltan. 2004. Cutaneous perception of electrical direct current. *ITBM-RBM* 25, 4 (2004), 240–243. DOI : <http://dx.doi.org/10.1016/j.rbmret.2004.09.012>
23. Nobuyuki Matsushita and Jun Rekimoto. 1997. HoloWall: Designing a Finger, Hand, Body, and Object Sensitive Wall. In *Proceedings of the 10th Annual ACM Symposium on User Interface Software and Technology (UIST '97)*. ACM, New York, NY, USA, 209–210. DOI : <http://dx.doi.org/10.1145/263407.263549>
24. Jon Moeller and Andruid Kerne. 2012. ZeroTouch: An Optical Multi-touch and Free-air Interaction Architecture. In *Proceedings of the SIGCHI Conference on Human Factors in Computing Systems (CHI '12)*. ACM, New York, NY, USA, 2165–2174. DOI : <http://dx.doi.org/10.1145/2207676.2208368>
25. Yasuaki Monnai, Keisuke Hasegawa, Masahiro Fujiwara, Kazuma Yoshino, Seki Inoue, and Hiroyuki Shinoda. 2014. HaptoMime: Mid-air Haptic Interaction with a Floating Virtual Screen. In *Proceedings of the 27th Annual ACM Symposium on User Interface Software and Technology (UIST '14)*. ACM, New York, NY, USA, 663–667. DOI : <http://dx.doi.org/10.1145/2642918.2647407>
26. Adiyani Mujibiya. 2015. Corona: Interactivity of Body Electrostatics in Mobile Scenarios Using Wearable High-Voltage Static Charger. In *Proceedings of the 17th International Conference on Human-Computer Interaction with Mobile Devices and Services (MobileHCI '15)*. ACM, New York, NY, USA, 435–444. DOI : <http://dx.doi.org/10.1145/2785830.2785888>
27. Yoichi Ochiai, Kota Kumagai, Takayuki Hoshi, Jun Rekimoto, Satoshi Hasegawa, and Yoshio Hayasaki. 2015. Fairy Lights in Femtoseconds: Aerial and Volumetric Graphics Rendered by Focused Femtosecond Laser Combined with Computational Holographic Fields. In *ACM SIGGRAPH 2015 Posters (SIGGRAPH '15)*. ACM, New York, NY, USA, Article 72, 1 pages. DOI : <http://dx.doi.org/10.1145/2787626.2792630>
28. The National Institute of Standards and Technology (NIST). 2008. EEEL Safety Rules for Moderate and High Voltages. Online. (1 October 2008). Retrieved September 21, 2016 from http://www.nist.gov/el/isd/mmc/upload/high_voltage_rules_revised.pdf.
29. Jun Rekimoto. 2002. SmartSkin: An Infrastructure for Freehand Manipulation on Interactive Surfaces. In *Proceedings of the SIGCHI Conference on Human Factors in Computing Systems (CHI '02)*. ACM, New York, NY, USA, 113–120. DOI : <http://dx.doi.org/10.1145/503376.503397>
30. Jun Rekimoto. 2009. SenseableRays: Opto-haptic Substitution for Touch-enhanced Interactive Spaces. In *CHI '09 Extended Abstracts on Human Factors in Computing Systems (CHI EA '09)*. ACM, New York, NY, USA, 2519–2528. DOI : <http://dx.doi.org/10.1145/1520340.1520356>
31. Jun Rekimoto, Takaaki Ishizawa, Carsten Schwesig, and Haruo Oba. 2003. PreSense: Interaction Techniques for Finger Sensing Input Devices. In *Proceedings of the 16th Annual ACM Symposium on User Interface Software and Technology (UIST '03)*. ACM, New York, NY, USA, 203–212. DOI : <http://dx.doi.org/10.1145/964696.964719>
32. Munehiko Sato, Ivan Poupyrev, and Chris Harrison. 2012. Touché: Enhancing Touch Interaction on Humans, Screens, Liquids, and Everyday Objects. In *Proceedings of the SIGCHI Conference on Human Factors in Computing Systems (CHI '12)*. ACM, New York, NY, USA, 483–492. DOI : <http://dx.doi.org/10.1145/2207676.2207743>
33. Rajinder Sodhi, Ivan Poupyrev, Matthew Glisson, and Ali Israr. 2013. AIREAL: Interactive Tactile Experiences in Free Air. *ACM Trans. Graph.* 32, 4, Article 134 (July 2013), 10 pages. DOI : <http://dx.doi.org/10.1145/2461912.2462007>
34. Daniel Spelmezan, Caroline Appert, Olivier Chapuis, and Emmanuel Pietriga. 2013. Controlling Widgets with One Power-up Button. In *Proceedings of the 26th Annual ACM Symposium on User Interface Software and Technology (UIST '13)*. ACM, New York, NY, USA, 71–74. DOI : <http://dx.doi.org/10.1145/2501988.2502025>
35. Yuriko Suzuki and Minoru Kobayashi. 2005. Air jet driven force feedback in virtual reality. *Computer Graphics and Applications, IEEE* 25, 1 (2005), 44–47. DOI : <http://dx.doi.org/10.1109/MCG.2005.1>

36. Yoshiki Takeoka, Takashi Miyaki, and Jun Rekimoto. 2010. Z-touch: A Multi-touch System for Detecting Spatial Gestures Near the Tabletop. In *ACM SIGGRAPH 2010 Talks (SIGGRAPH '10)*. ACM, New York, NY, USA, Article 57, 1 pages. DOI : <http://dx.doi.org/10.1145/1837026.1837100>
37. Emi Tamaki, Takashi Miyaki, and Jun Rekimoto. 2011. PossessedHand: Techniques for Controlling Human Hands Using Electrical Muscles Stimuli. In *Proceedings of the SIGCHI Conference on Human Factors in Computing Systems (CHI '11)*. ACM, New York, NY, USA, 543–552. DOI : <http://dx.doi.org/10.1145/1978942.1979018>
38. Chat Wacharamanatham, Kashyap Todi, Marty Pye, and Jan Borchers. 2014. Understanding Finger Input Above Desktop Devices. In *Proceedings of the SIGCHI Conference on Human Factors in Computing Systems (CHI '14)*. ACM, New York, NY, USA, 1083–1092. DOI : <http://dx.doi.org/10.1145/2556288.2557151>
39. Malte Weiss, Chat Wacharamanatham, Simon Voelker, and Jan Borchers. 2011. FingerFlux: Near-surface Haptic Feedback on Tabletops. In *Proceedings of the 24th Annual ACM Symposium on User Interface Software and Technology (UIST '11)*. ACM, New York, NY, USA, 615–620. DOI : <http://dx.doi.org/10.1145/2047196.2047277>
40. Andrew D. Wilson. 2010. Using a Depth Camera As a Touch Sensor. In *ACM International Conference on Interactive Tabletops and Surfaces (ITS '10)*. ACM, New York, NY, USA, 69–72. DOI : <http://dx.doi.org/10.1145/1936652.1936665>
41. Andrew D. Wilson and Hroje Benko. 2010. Combining Multiple Depth Cameras and Projectors for Interactions on, Above and Between Surfaces. In *Proceedings of the 23rd Annual ACM Symposium on User Interface Software and Technology (UIST '10)*. ACM, New York, NY, USA, 273–282. DOI : <http://dx.doi.org/10.1145/1866029.1866073>
42. Graham Wilson, Martin Halvey, Stephen A. Brewster, and Stephen A. Hughes. 2011. Some Like It Hot: Thermal Feedback for Mobile Devices. In *Proceedings of the SIGCHI Conference on Human Factors in Computing Systems (CHI '11)*. ACM, New York, NY, USA, 2555–2564. DOI : <http://dx.doi.org/10.1145/1978942.1979316>
43. Jacob O. Wobbrock, Leah Findlater, Darren Gergle, and James J. Higgins. 2011. The Aligned Rank Transform for Nonparametric Factorial Analyses Using Only ANOVA Procedures. In *Proceedings of the SIGCHI Conference on Human Factors in Computing Systems (CHI '11)*. ACM, New York, NY, USA, 143–146. DOI : <http://dx.doi.org/10.1145/1978942.1978963>
44. Thomas G. Zimmerman, Joshua R. Smith, Joseph A. Paradiso, David Allport, and Neil Gershenfeld. 1995. Applying Electric Field Sensing to Human-computer Interfaces. In *Proceedings of the SIGCHI Conference on Human Factors in Computing Systems (CHI '95)*. ACM Press/Addison-Wesley Publishing Co., New York, NY, USA, 280–287. DOI : <http://dx.doi.org/10.1145/223904.223940>